

WATER PROCESS SOLUTIONS

Dry Chemical Feed Systems

Sales Literature No. WPSL01100



Introduction

Series 32-055 Volumetric Screw-Type Feeder

The Series 32-055 volumetric feeder is designed to give reliable service feeding various water and wastewater chemicals as well as industrial chemicals. Capacity is 0.03 to 50 cubic feet per hour. The operating range of the feeder is 20:1, but this is extendable to 60:1 by belt position and a stepped drive pulley.

The feeder consists of an SCR variable-speed drive in a NEMA 12 enclosure: DC motor with 4 step pulley; and worm-and-wormwheel gearbox.

The feeder features chemical-resistant plastic and stainless steel construction, design simplicity and variable speed control in three arrangements:

- Manual
- Start-stop
- Automatic from a 1-5,4-20 or 1-50 mA DC control. The automatic option includes a manual dosage control and alternate start-stop or local manual control.

Key Benefits

- Dependable and Reliable Feeding
- Choice of Control Arrangements
- Economical Feeder Installations
- Wide Range of Capacities
- Chemical Resistant Construction

General

The feed screw comes in 3/4-, 1 1/2-, 2 1/2-, and 4- inch diameter nominal sizes. Parts which contact the product are made of stainless steel, fiber glass, and Buna N for maximum chemical resistance. Parts which contact the product can be supplied in stainless steel and white vinyl nitrile, materials acceptable under many FDA food-additive regulations.

The feeder can be supplied with: 4-20 mA DC output signal proportional to motor speed; a 25-gallon polyethylene, a 35-gallon fiber glass, or a 35-gallon stainless steel solution tank with jet mixing; float valve, dust arrester; mechanical mixer, carbon-wetting mixer and draft tube; 1000-lb or 3000-lb mounting stand; 1000-lb weighing scale and loss-of-weight recorder. Hoppering can include converging, loading, extension, storage hoppers, dust collectors, bag loaders, accessories and installation hardware.



Wide Choice of Control Arrangements

Manual Control Arrangement: This arrangement gives manual variable-speed control of feed rate. An SCR variable-speed drive gives continuously adjustable feed rate settings over a 20:1 range (extendable to 60:1 using adjustable-step drive pulley). An SCR control unit varies the speed of the DC motor according to a potentiometer-position input. This potentiometer, calibrated 0-100% of maximum capacity, is on the feeder control panel. The panel also has a power on-off switch and run-stop switch.

Automatic Start-Stop Arrangement : This arrangement gives start-stop control of feeder delivery. It responds to such inputs as: switch closure by a pulse duration signal from a flow-proportional source; high-low switch closure from a level sensor; or a remote manual switch. Feed rate, however, is varied by manual variable speed control. An SCR variable-speed drive gives continuously adjustable feed rate settings over a 20:1 range (extendable to 60:1 using adjustable-step drive pulley). An SCR control unit varies the speed of the DC feeder motor according to a potentiometer-position input. This potentiometer, calibrated 0-100% of maximum capacity, is on the feeder control panel. The panel also has a power on-off switch, a selector switch for local manual or remote start-stop control of feeder delivery.

Automatic (mA)-Manual Arrangement: This open-loop arrangement is ideal for continuous, automatic process control systems or flow-proportional applications. It is the only volumetric available which offers four separate control modes in one feeder. They are: automatic feed rate control from a 1-5, 4-20, 10-50 mA or 0-10 V DC signal; manual feed rate control by potentiometer position; start-stop control of feeder delivery via, switch closure from a pulse duration or other source; and manual dosage control.

An SCR variable-speed drive permits continuously adjustable (manual) feed rate settings over a 20:1 range (extendable to 60:1 using adjustable-step drive pulley). An SCR control unit varies the speed of the DC feeder motor according to the mA signal value or the manual potentiometer position. This potentiometer, calibrated 0-100% of maximum capacity, is on the feeder control panel. The panel also has a power on-off switch; selector switch for automatic or manual control of feed rate; selector switch for local manual or remote start-stop control of feeder delivery.

Also included is a potentiometer for manual dosage of chemical feed when the feeder is on automatic control. The automatic mA feeder arrangement can have an optional 4-20 mA DC output signal (into 0-800 ohms) proportional to motor speed. An integral part of the control assembly, this accessory can be used as: a speed-feedback signal for closed loop control of feed rate; an alternate means of remote speed (inferentially feed rate) indication; or for proportional control of related equipment.

Economical Feeder Installations

A variety of optional accessories provide custom feeder installations with economy. The feeder is available alone, mounted on a solution tank, or mounted on a stand beside the tank. The feeder can be scale mounted with a loss of weight recorder added. Solution tanks can be 25-gallon polyethylene or 35-gallon fibre glass or stainless steel. A float valve, dust-and-fume arrester, and mechanical mixer can be added to the tanks. Also available are packaged feeder-solution tank systems with 6 tank sizes from 35 to 500 gallons. A complete line of hopping components includes bag loaders, dust collectors, and hoppers in many styles and sizes along with accessories and installation hardware. The feeder hopper is designed to support up to 1000 lb.

Chemical Resistant

Standard materials resist such corrosive chemicals as alum and ferric sulphate. The feed screw, discharge spout, and hopper bottom trough are stainless steel, the hopper and base are molded fiberglass. In the arrangement with hopperwall agitation, the agitators are sealed behind Buna N diaphragms. The feeder is designed to handle many difficult chemicals.

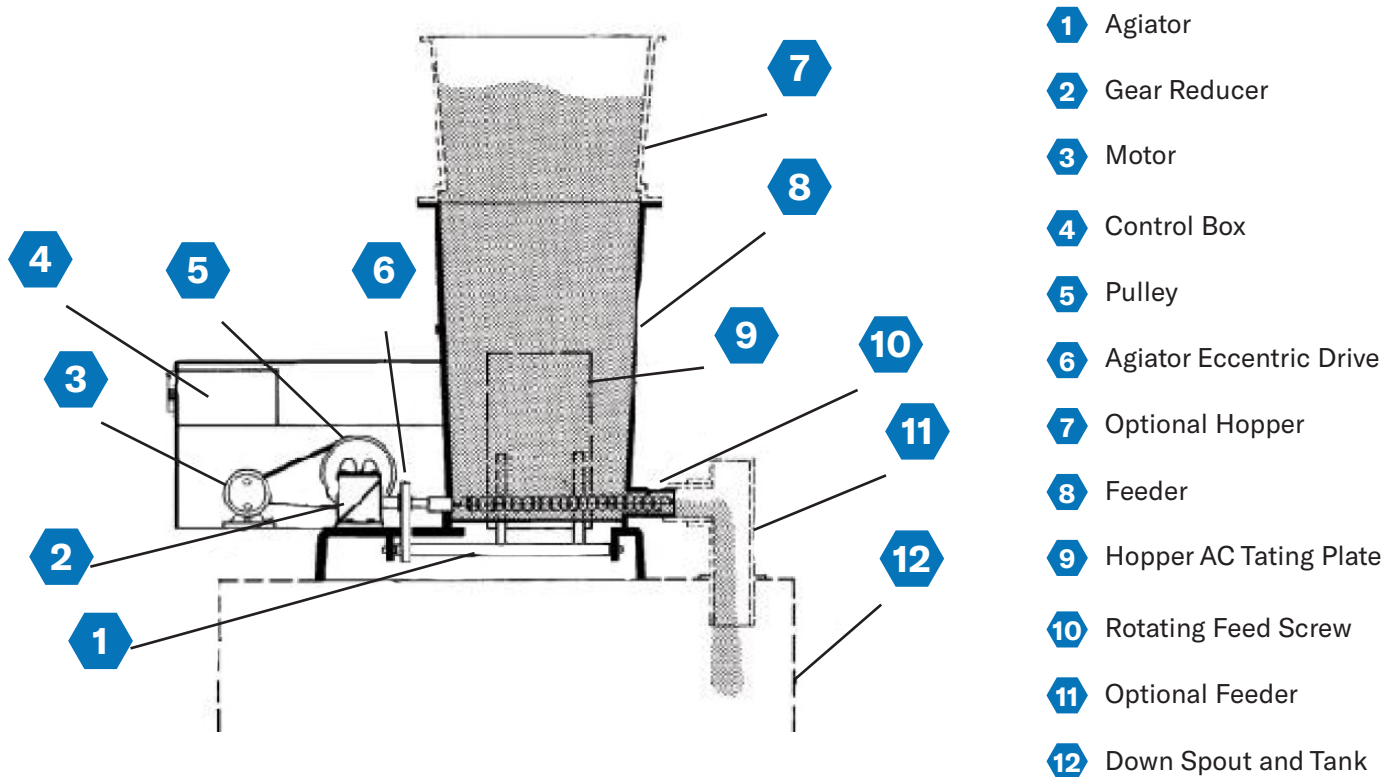

Food-additive Feeder

In this optional arrangement, parts which contact the product are made of materials acceptable under many FDA food-additive regulations: the hopper, feed screw, and discharge spout are stainless steel; the hopper agitators are FDA approved white vinyl nitrile.

Factory Mutual (FM) Approved Arrangements For Hazardous Locations

The Series 32-055 Volumetric Feeder is available in an optional arrangement for hazardous locations. The DC motor is a dust-ignition proof * type; feeder controls are in a NEMA 12 enclosure for mounting in a non-hazardous area remote from the feeder. The feeder is FM approved for Class 11, Division 1. Groups E, F, & G hazardous locations*. An arrangement for mounting controls in a Class II area can be provided. Consult for specifics.

Design Simplicity For Dependable Feeding

This durable feeder features a proven SCR variable speed drive, simple worm-and-worm-wheel gearbox with few moving parts, a helical feed screw, and single-ended discharge. It is designed to do a reliable feeding job at low cost.

Options For Difficult-to-Handle Materials

For smooth feeding of materials which tend to cake, arch, or pack, an arrangement with hopper agitation is available.

Wide Feed Range Selection

Operating range provided by the variable-speed drive is 20: 1. But this is extendable to 60: 1 by changing belt position on the 3: 1 ratio, 4 step drive pulley. This and a choice of 4 feed screw sizes provides a variety of capacities between 0.03 and 50 cubic feet per hour.

Optional Accessories

Solution Tanks

These tanks can be cylindrical 25-gallon polyethylene or rectangular 35-gallon fibre glass or stainless steel. (Five tank sizes between 75 and 500 gallons are available). The tanks have overflow, drain, and discharge connections and mixing by submerged triple jet. Where additional mixing is required, optional mechanical mixers can be supplied. Also available: feeder-tank mounting plate and hardware; inspection cover; feeder downspout and adapter for side mounting of feeder.

Hopper Low Level Switch

A built-in hopper switch is available as an option. The switch closes or opens a contact to actuate customer's alarm or control device. This switch eliminates the need for special hopping or external level switches. (Factory Mutual approved for Class II, Division 1, Groups E, F and G hazardous locations as defined by Article 500, NEC.)

Float Valve

Plastic or brass float valves for automatic tank filling in 6 or 30 gpm cap. Special Carbon Mixer for carbon and other difficult-to-wet materials, a special mechanical mixer with a draft tube (submerged baffle ring) is available (except 25-, 350-, and 500- gallon solution tanks).

Mechanical Mixers

For mounting on any solution tank; stainless steel shaft and impeller. See Technical Data.

Dust Arrester

Water-spray-operated dust-and-fume arrester for mounting on solution tank.

Stands

Rugged steel stands so feeder can be mounted on the floor or beside a solution tank. Stands come in models which support 1000 or 3000 lb.

Scales

Feeders can be equipped with 1,000-lb portable beam scales. Feeder with hopper and stand are mounted on the scale platform. After initial tare-weight adjustment, only the material in the hopper is weighed. Any feeder (except arrangements with 4-inch feed screws) can be scale mounted for side delivery into a 25-gallon or 35-gallon solution tank Loss-of-Weight Recorder and Scale This option provides a graphic and permanent record of material consumed by recording loss of weight on a Low 748 Scale and Loss of Weight Recorder. It has a calibration accuracy of 0.5% of full scale and can be supplied with 24-hour or 7-day circular charts in ranges of 100, 150, 200, 250, 300, 400, 500 or 600 lb. Relay contacts are provided to operate a signal light or audible alarm to indicate when material is depleted.

Hoppering Systems

UGSI Chemical Feed, Inc. supplies optional hoppering components to meet almost any installation requirement. These include converging, loading, extension, and storage hoppers in square or cylindrical shapes and a variety of sizes. They also offer a choice of floor-above-supported or feeders-supported configurations. Dust collectors are available in a variety of sizes, floor-mounted or feedersupported. Bag loaders come in 1 or 2- bag models. Hopper accessories include screens, covers, shut-off gates, flexible connections, and installation hardware. A plate adapts dust collectors and bag loaders to cylindrical hoppers of various diameters (2, 3, or 4 ft).

Hazardous-Location* and Hopper-Agitation Arrangements

Optional arrangements for hazardous location service and with hopper agitation are described under Features. *As defined by Article 500 NEC. Technical Data Accuracy With uniform, free-flowing materials, accuracies of 1% to 2% of full scale can be achieved. It must be realized however, that with material delivery controlled on a basis of volume, many factors apply: material flow-ability, density at the feed screw, hopper size and shape are only a few of the factors which determine accuracy. Actual accuracy can be established only by running sample material test at the feeder installation.

Operating Range

20:1 extendable to 60:1 by changing belt position on the 3: 1 ratio, 4-step drive pulley.

Feeder Motors

Standard arrangement; 1/6 hp, permanent-magnet, 90-volt DC, TENV; hazardous-location arrangement, 1/4 hp, permanentmagnet, DC, dust-ignition-proof*. The SCR control for these motors requires 115 volt, 50/60 Hz, single-phase power supply, 4 amps. *As defined by Article 500 National Electric Code.

Electrical Connection

Conduit connection to coded terminal strip.

Materials of Construction

Standard: upper hopper, fiberglass: hopper-wall agitators, Buna N; feed screw, discharge spout, and hopper-bottom trough, stainless steel.

Weight and Shipping Weight

210 lb and 280 lb.

Technical Data

To select the gearbox and screw size for a particular application, consider both the volumetric and gravimetric feed rate limits and the desired operating range:

- ◆ Determine maximum gravimetric feed rate required in lb/hr.
- ◆ Divide maximum gravimetric feed rate (lb/hr) by density of material (lb/cu ft) to determine maximum volumetric feed rate (cu ft/hr) required.
- ◆ Select proper screw size-gearbox combination taking into account the desired feed rate range.

Note: If the maximum required feed rate (for other ratios refer to not below) High Speed Gearbox (Rates are based on average density at feed screw).

Maximum Volumetric Capacities (cu ft/hr)									
Low Speed Gearbox						High Speed Gearbox			
4-Step	Drive Pulley	Screw Size				Screw Size			
Step	Ratio	3/4"	1 1/2"	2 1/2"	4"	3/4"	1 1/2"	2 2/12"	4"
1	12:1	0.03	0.2	1.0	2.5	0.10	0.8	4	10
2	8:1	0.04	0.3	1.5	3.7	0.16	1.2	6	15
3	5:3:1	0.06	0.45	2.2	5.7	0.24	1.8	9	22
4	4:1	0.08	0.6	3.0	7.5	0.32	0.32	12	30
4	2:7:1*	-	-	-	-	-	-	-	50

Typical Maximum Feed Rates					
Feed Screw Size	3/4"	1 1/2"	2 1/2"	4"	4"***
Pulley Ratio	4:1	4:1	4:1	4:1	2:7:1
Aluminum Sulfate-granular Density 21lb./cu. ft.	21	168	750	2100	3125
Activated Carbon-powder Density 21lb./cu. ft.	6	40	243	*	*
Diatomaceous Earth Density 20lb./cu. ft.	*	28	153	468	*
Ferric Sulfate-granular Density 64lb./cu. ft.	22	154	725	1930	2914
Calcium Hydroxide (Lime)-Power Density 26lb./cu. ft.	6	45	334	990	1500
Sodium Carbonate (Soda Ash) Density 42lb./cu. ft.	13	94	443	1157	1725

* Not recommended

** 4" screw with extended range drive pulley

NEMA is a trademark of the National Electrical Manufacturers Association. NEC is a trademark as National Electrical Code. The information provided in this literature contains merely general descriptions or characteristics of performance which in actual case of use do not always apply as described or which may change as a result of further development of the products. An obligation to provide the respective characteristics shall only exist if expressly agreed in the terms of a written contract.



www.waterprocesssolutions.com
enquiries@waterprocesssolutions.com

 Water-Process-Solutions

 @waterwps

Water Process Solutions Ltd
Unit 10,
Mill Hall Business Estate,
Aylesford,
Kent, ME20 7JZ

WATER PROCESS
 **SOLUTIONS**

Sales Literature No. WPSL01100
Revision No. 1 24/07/2019